

# Nora

2-SEATER MODULE, LEFT



---

Nora is a contemporary modular sofa that can be combined to suit any sofa dream possible. The modules are designed in soft, curving silhouettes and thus challenge the traditional perception of the sofa as a square box. This Nora 2-seater left module makes it possible to create a sculptural sofa anywhere, shaping it as a wave or maybe even as an entire circle. Nora is brimming with possibilities, no matter if the space is vast or tiny.

**SOFACOMPANY**

## MATERIAL COMPONENTS

Frame: FSC wood 100%  
Foam: High Resilience Fire Retardant Foam  
Legs: Wood: FSC wood 100%  
Surface meets requirements of.:  
Reach, Painted: standard 16 CFR 1303 – PASS

## SAFETY AND STABILITY

Our products are always developed and tested against EN 16139. 1 & 2.  
EN-1021 1 & 2, BS5852 0 & 1, CA TB 117-2013.

## PACKAGING MATERIAL & SHIPPING

The use of packaging materials are minimized without compromising protection of the product during transport. Chairs and sofas are protected in a cardboard box and when needed wrapped in a protective layer of recycled plastic. Shipping and transportation is in addition CO2 neutral.

## PACKAGE MEASUREMENTS

85 x 153 x 92 cm, 42 kg

## WARRANTY

Warranty against manufacturing defects (materials and craftsmanship) is standard as follows:

Frame: Lifetime  
Foam: 5 years  
Upholstery/Fabric: 5 years

Wear, tear and damages to the products are not covered under this warranty.

## TEXTILE

See our textiles [here](#)

## DESIGNER

Mathias Mouritsen

## 2-SEATER MODULE, LEFT

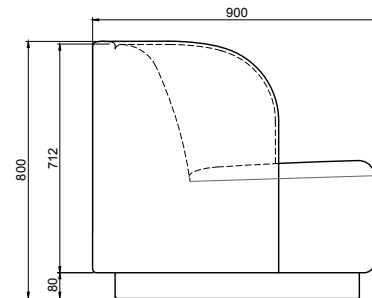
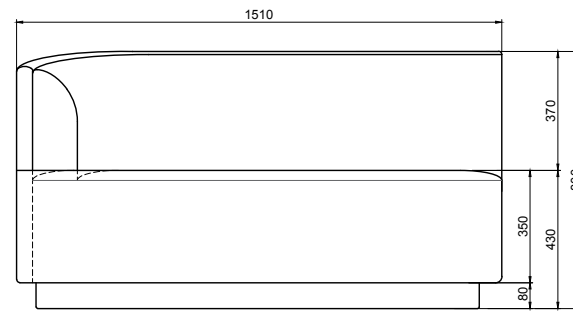

1-SEATER MODULE

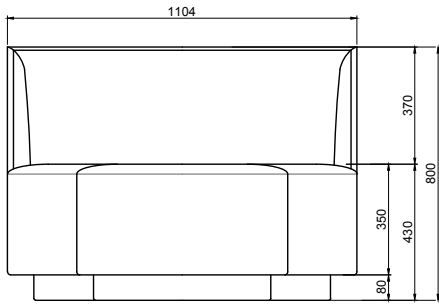

2-SEATER MODULE, RIGHT

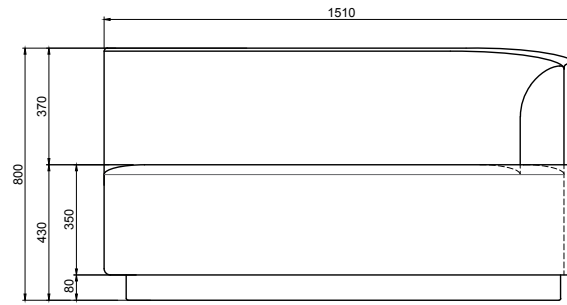

2-SEATER CHAISE LOUNGE MODULE, LEFT

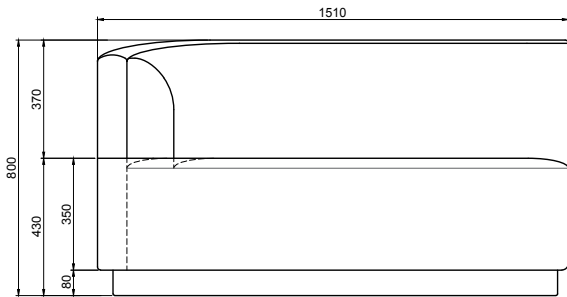

2-SEATER CHAISE LOUNGE MODULE, RIGHT

